

FUNDAMENTALS OF CRAWLSPACE DESIGN & CONSTRUCTION IN PA

June 2015 | Christopher Hine

INTRODUCTION

A crawlspace in residential construction can be a viable option when dealing with certain circumstances, such as poor site conditions, but the design and construction of a crawlspace can be quite challenging. Beyond poor site conditions, many factors should be taken into account with crawlspace design and construction, including consumer preference, construction cost, flexibility of mechanical systems, and the incorporation of the crawlspace into the building enclosure. Knowledge of the building science behind moisture in a crawlspace is a critical design consideration relating to durability and sustainability. This document will discuss code requirements for crawlspaces along with some best practice designs for climate conditions in Pennsylvania.

WHAT IS A CRAWLSPACE?

The International Residential Code (IRC) does not provide a definition for the term "crawlspace." As stated by Merriam-Webster, a crawlspace is a space under the

first floor or a roof of a building that is not high enough in which to stand up. For the purpose of this document, we will focus on the space under the first floor. This space should be viewed as a short basement (see Figure 1).

WHY DESIGN A CRAWLSPACE?

This document will review three reasons why one might design a crawlspace. These considerations include cost effectiveness, site conditions, and flexibility.

Cost Effective Alternative

When using a cast-in-place concrete wall, a cost savings can potentially be achieved by simply using less material for the wall. The reduction of height from a 96" full height basement wall to a 36" crawlspace wall could bring savings of between 30%-40% depending on the market. These savings could increase if a foundation wall system such as a concrete masonry block wall was chosen in the design phase.

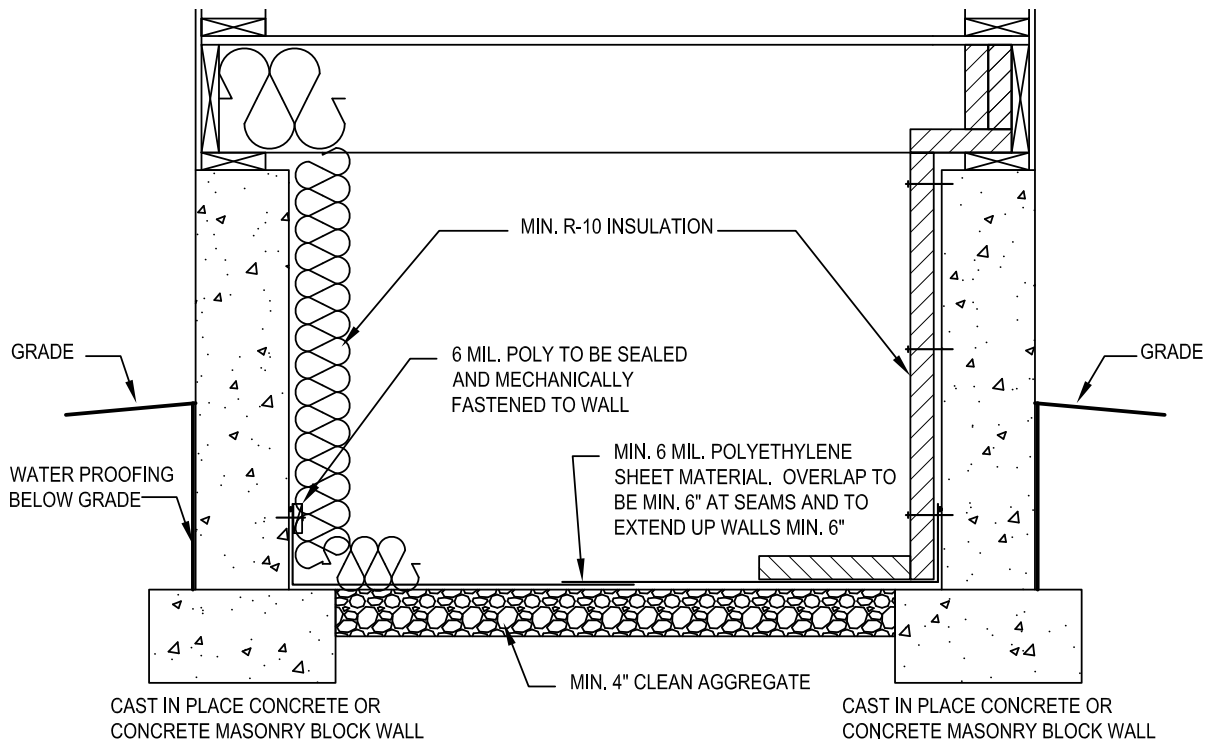

Figure 1: Typical design options for crawlspaces

Site Conditions

Site conditions play a vital role when designing structures. Sites that contain shallow bedrock or a high ground water table can be good candidates for the design and construction of a crawlspace. One way to reduce the risk of unknown site conditions is to dig test pits within the footprint of the structure prior to finalizing the design.

Flexibility

A crawlspace can also introduce flexibility when comparing it to other forms of construction. For instance, when comparing to a slab on grade, a crawlspace allows the designer to place mechanical systems such as HVAC equipment inside a space that can be conditioned. This option also allows for plumbing to be installed in a conventional manner as opposed to being installed under the slab.

WHAT ARE THE CODE REQUIREMENTS FOR A CRAWLSPACE?

The code requirements for a crawlspace that is designed and constructed in the Commonwealth of Pennsylvania can be found in Section R408 in the 2009 IRC.

This section covers Ventilation (R408.1), Openings for under-floor ventilation (R408.2), Unvented crawlspace (R408.3), Access (R408.4), Removal of debris (R408.5), Finished grade (R408.6), and Flood resistance (R408.7), not all of which are covered in this document.

Vented Crawlspace Design

Designing a vented crawlspace follows specific ventilation requirements set forth in the 2009 IRC (see Figure 2). This requirement states the following:

The under-floor space between the bottom of the floor joists and the earth under any building (except space occupied by a basement) shall have ventilation openings through foundation walls or exterior walls. The minimum net area of ventilation openings shall not be less than 1 square foot (0.0929 m²) for each 150 square feet (14 m²) of under-floor space area, unless the ground surface is covered by a Class 1 vapor retarder material. When a Class 1 vapor retarder material is used, the minimum net area of ventilation openings shall not be less than 1 square foot (0.0929 m²) for each 1,500 square feet (140 m²) of under-floor space area. One such ventilating opening shall be within 3 feet (914 mm) of each corner of the building.

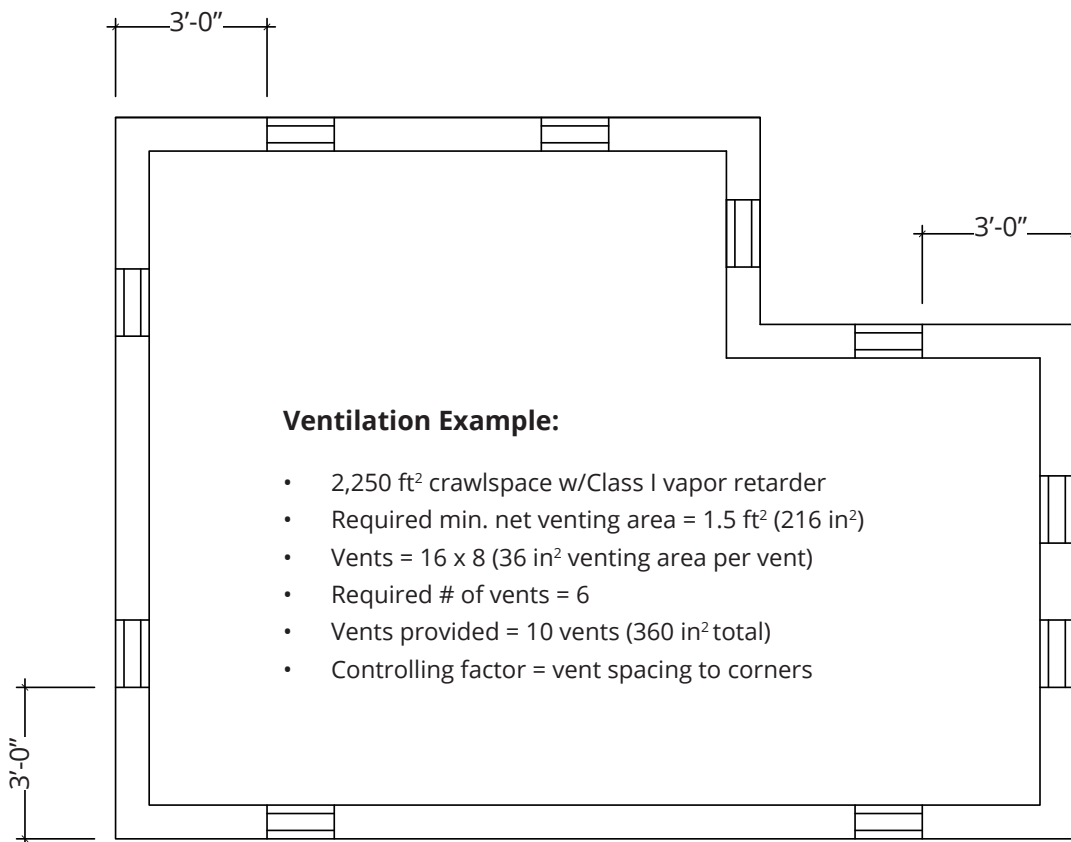

Figure 2: Example Layout of Vented Crawlspace (not to scale)

Unvented Crawlspace Design

The 2009 IRC also allows you to design an unvented crawlspace. This design eliminates the need for the installation of openings which allow outside, unconditioned air to ventilate the space. The option for an unvented design comes with the following requirements:

1. *Exposed earth is covered with a continuous Class I vapor retarder. Joints of the vapor retarder shall overlap by 6 inches (152 mm) and shall be sealed or taped. The edges of the vapor retarder shall extend at least 6 inches (152 mm) up the stem wall and shall be attached and sealed to the stem wall; and*
2. *One of the following is provided for the under-floor space:*
 - 2.1. *Continuously operated mechanical exhaust ventilation at a rate equal to 1 cubic foot per minute (0.47 L/s) for each 50 square feet (4.7m²) of crawlspace floor area, including an air pathway to the common area (such as a duct or transfer grille), and perimeter walls insulated in accordance with Section N1102.2.9;*
 - 2.2. *Conditioned air supply sized to deliver at a rate equal to 1 cubic foot per minute (0.47 L/s) for each 50 square feet (4.7 m²) of under-floor area, including a return air pathway to the common area (such as a duct or transfer grille), and perimeter walls insulated in accordance with Section N1102.2.9;*
 - 2.3. *Plenum in existing structures complying with Section M1601.5, if under-floor space is used as a plenum.*

THE BUILDING SCIENCE IN CRAWLSPACE DESIGN

Building science has the power to influence certain design characteristics in residential construction. This holds true, especially with the design of a crawlspace in Pennsylvania. One of the driving factors of careful design is moisture. Summertime humidity and crawlspace temperature can be a recipe for concern throughout Pennsylvania.

Relative Humidity and Vented Crawlspace Design

The 2009 IRC allows for a vented crawlspace, but is that design the best option for Pennsylvania? Relative humidity is directly impacted by temperature. The relative humidity of an air-water mixture is defined as the ratio of the partial pressure of water vapor in the mixture to the saturation pressure at a given temperature. In other words, the higher the temperature, the higher the amount of water vapor the air can hold. When that same warm, humid air is cooled, condensation will occur once the dew point temperature is reached. See Figure 3 for this scenario within a vented crawlspace.

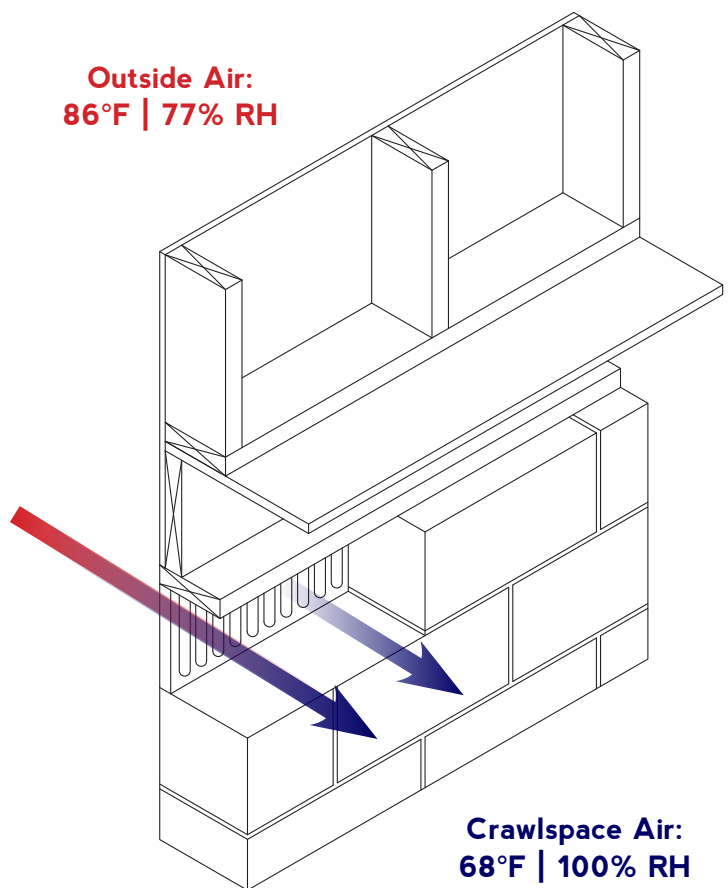

Figure 3: Example of conditions that could lead to moisture issues in a crawlspace:

Relative humidity will increase as temperature decreases. If the outside air temperature and relative humidity is high enough, 100% relative humidity can be reached once the air has been cooled inside the crawlspace, creating condensation. This moisture can potentially lead to rot and deterioration of building materials. This is a common scenario in climates throughout Pennsylvania.

REDUCING CONDENSATION RISKS IN CRAWLSPACES

Reducing the risk of condensation is a sure way to help increase the durability and longevity of any crawlspace. In following the requirements set fourth in section R408.3 (Unvented Crawlspace) out of the 2009 IRC, best practice design concepts and Figures 4 and 5 are likely to reduce the risk of condensation and provide a healthy, clean crawlspace.

Design Concepts to Reduce Moisture

By following the unvented crawlspace provision in the 2009 IRC and a few best practice considerations, the risk of moisture accumulation can be reduced.

Refer to the following considerations :

1. **Provide capillary break between footing and wall**
2. **Waterproof exterior side of crawlspace wall**
3. **Install minimum Class I vapor retarder on grade, tape all seams and extend up stem wall a minimum of 6 inches and mechanically fasten to wall**
4. **Provide 1 cfm per 50 sq ft of continuous mechanical exhaust ventilation or 1 cfm per 50 sq ft conditioned air to crawlspace area**
5. **Insulate walls to a minimum of R-10**
6. **Review figures 4 and 5.**

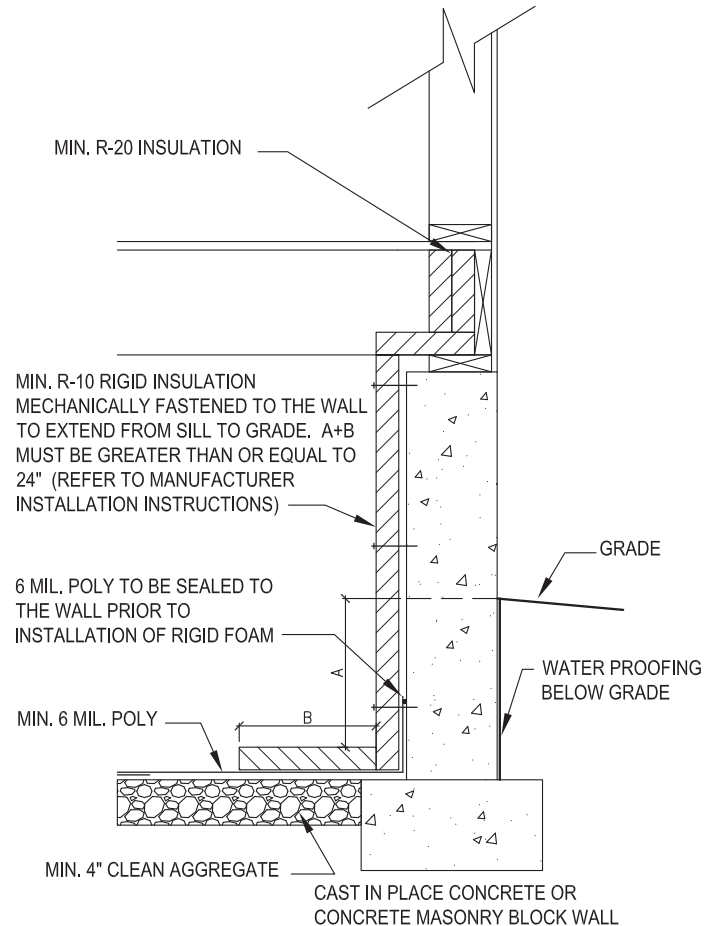
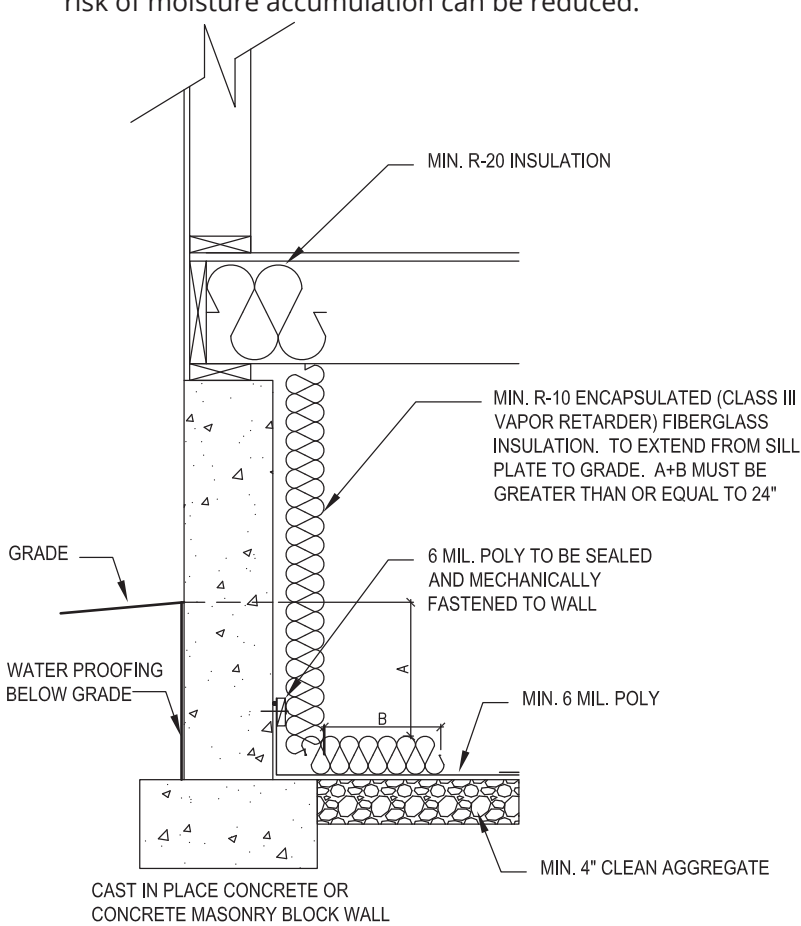

Figure 4: Unvented crawlspace with fiberglass insulation

Figure 5: Unvented crawlspace with rigid foam insulation

This publication is available in alternative media on request.

Penn State is an equal opportunity, affirmative action employer, and is committed to providing employment opportunities to minorities, women, veterans, individuals with disabilities, and other protected groups. Nondiscrimination: <http://guru.psu.edu/policies/AD85.html>. U.Ed. ENG 16-24



The Pennsylvania Housing Research Center (PHRC) exists to be of service to the housing community, especially in Pennsylvania. The PHRC conducts technical projects—research, development, demonstration, and technology transfer—under the sponsorship and with the support of numerous agencies, associations, companies, and individuals. Neither the PHRC, nor any of its sponsors, makes any warranty, expressed or implied, as to the accuracy or validity of the information contained in this report. Similarly, neither the PHRC, nor its sponsors, assumes any liability for the use of the information and procedures provided in this report. Opinions, when expressed, are those of the authors and do not necessarily reflect the views of either the PHRC or its sponsors. It would be appreciated, however, if any errors, of fact or interpretation or otherwise, could be promptly brought to our attention.